

***Klemsan***<sup>®</sup>



**KLECARD**  
USER GUIDE

***Klemsan***<sup>®</sup>

## Dear Valued Customer

---

Thank you for choosing Klemsan Marking Solutions.

**Klecard** is the perfect all-in-one solution that using thermal transfer printing technology to produce professional looking industrial marking labels. A wide variety of products are available in our range, suitable to mark terminal blocks, cables and any other component inside and outside the electric panels.

Operation is simple and fast once a job has been created with our dedicated labeling software **Klemark Pro**.

To begin using your Klecard, please read this manual carefully.

This User Guide is a complete step-by-step guide to quickly and easily create all your projects with your new printer.

---

---

Klemsan reserves the right to make improvements to the equipment and software described in this document at any time without any prior notice. Klemsan reserves the right to revise this publication and to make changes from time to time in the content hereof without obligation of Klemsan to notify any person or organization of such revisions or changes.

This document may contain links to web sites that were current at the time of publication, but may have moved or become inactive since. This document may contain links to sites on the Internet that are owned and operated by third parties.

Klemsan is not responsible for the content of any such third-party site.

© 2019, Klemsan

---

**Corporate Headquarters / Service Address:**

Kızılızüm Cad. No:15 Kemalpaşa - İZMİR

Tel: +90 (232) 877 08 00 / Fax: +90 (232) 877 08 06

[www.klemsan.com](http://www.klemsan.com)

**Trademark Acknowledgments:**

Windows is a registered trademark of Microsoft Corporation.

All other trademarks are the property of their respective owners.

## Technical Support Information

### Klemsan Website

[www.klemsan.com](http://www.klemsan.com)

For your support requests, you can reach

[klemsanmarketing@klemsan.com.tr](mailto:klemsanmarketing@klemsan.com.tr) by email.



Please do not forget to share the following information when you contact to support services.

- Serial number of Klecard printer,
- Software version and serial number of software,
- Exact error message that shown on the display,
- Functional and technical description of the problem.

### IMPORTANT

You should register a license to use the software successfully.

You can contact with our regional sales representatives for that process.

# Contents

---

Klecard Specifications .....	7
Unpacking and Inspection .....	8
Choosing a Good Location .....	8
Introduction to Klecard .....	9
Identify the Parts of the Printer .....	10
Human Interface.....	10
Control Panel .....	11
Back of the Printer .....	12
Sensors of the Klecard .....	13
Operating of the Klecard Printer.....	14
Energizing the Printer .....	15
Installing the Plates and the Media.....	16-17
Setting the Intensity .....	18
Ribbon Control .....	19
Maintenance of the Klecard .....	20-21
Changing the Ribbon .....	22-24
Troubleshooting .....	25
Printing Issues .....	26
Safety Information .....	27-28
Warranty .....	29

# KLECARD Specifications

<b>Technology</b>	Thermal transfer
<b>Quality</b>	<b>300 x 600 dpi</b>
<b>Speed</b>	Up to 1 inch per second
<b>Temperature</b>	<b>+15°C + 35°C</b>
<b>Relative humidity</b>	30% to 85% without condensation
<b>Printable width</b>	105 mm
<b>Printable area</b>	<b>105 x 140 mm max</b>
<b>Connection</b>	USB 2.0
<b>Voltage</b>	24V DC / 3.75A
<b>Ink</b>	300 mt resin ribbon
<b>Certification</b>	CE
<b>Print resistance</b>	CEI 16-7, EN 60950-1, EN 61010-1, EN 60464-2
<b>Dimensions</b>	393 (L) x 230 (W) x 244 (H) mm
<b>Weight</b>	9,5 Kg
<b>Driver</b>	Windows 7, Windows 8, Windows 10
<b>Graphics</b>	Bitmaps, barcodes, vectors and text
<b>Other</b>	Ribbon saving algorithm
	Built-in printhead monitoring
	Automatic printhead temperature detection
	Built-in diagnostic tests
<b>Human interface</b>	2 button, 2 x 16-digit LCD Display

## Unpacking and Inspection

---

While unpacking your Klecard, inspect the carton to ensure that no damage has occurred during shipping. Make sure that all supplied accessories are included with your unit.

The following items should be included:

- Klecard Printer
- Cardboard Core for Ribbon
- Plate for Terminal Block Tags
- Plate for Flat Media
- Power Supply
- Power Cord
- USB Cable



If you ever need to transport the Klecard and any of its parts in the future, saving the carton box and packaging materials is recommended.

**When the unpacking is done, please see page 14.**

## Choosing a Good Location

---

- Place the Klecard in a location with adequate air circulation to prevent internal heat build up.
- You will need at least **20-25 cm** of front space to fully open the tray.
- **Do not place** the Klecard near heat sources such as radiators or air ducts, or in a place subject to direct sunlight, excessive dust, mechanical vibration or shock.
- Due to the low noise emitted during operations, Klecard can be placed in your workshop and on your desk in the office as well.

# Introduction to Klecard

---

This manual provides the information needed to set up, install, and operate the Klecard printer and to identify the parts.

## Operating system requirements

The Klecard is compatible with Windows 7, Windows 8 and Windows 10 OS. It requires one USB port on your computer.

## Media requirements

To ensure the best printing quality and efficiency, only Klemsan original consumables must be used which have a special surface quality for thermal printing.

## Plate for media

Klecard can operate only with its original positioning plates. With these plates, you can print all kind of Klemsan labels.

## Ribbons

The Klecard printer requires original ribbon that specially produced for this printer with high temperature resistance and high resin density features.

The supply and the rewind ribbon core are produced with special notches for an easy insertion on the rollers.

The ribbon are made in premium resin quality, for the best printing output on the consumables offered by the Klemsan range.

## Software

Klecard can be used with Klemsan branded software called “Klemark Pro”.

## Identify the Parts of the Printer

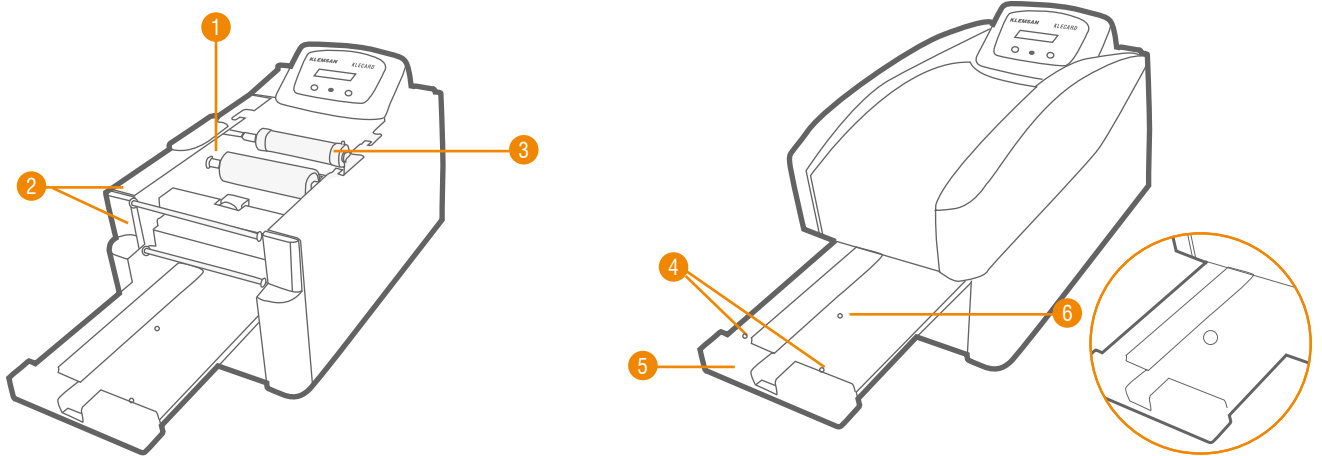

1	Rewind Roller
2	Front Ribbon Guides
3	Supply Roller
4	Fixing Pins
5	Tray Cover
6	Centering Pin

## Human Interface

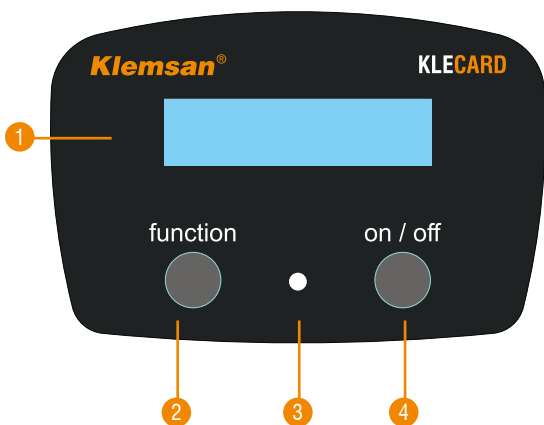

Klecard has an LCD screen on which you can read the necessary controls and settings. The on/off button is used to energize the printer. The Klecard has a VI-rated efficiency power supply and it is energy star compliant. Thanks to that, the unit consumes virtually no power when it's off. A separate Function Button is used to control the tray. This button is working with the LED under firmware control; the LED light is activated when the media sensor is detecting the label.

1	Display
2	Function Button
3	LED
4	ON-OFF Button

# Control Panel

## Function Button

This button opens and closes the printer tray. With this button it is possible to make some other choices. When you need to stop the printing session, you can press the Function Button and the job is cancelled.

## LED Indicator

The LED reflects conditions of the Klecard.



**Printer OFF**

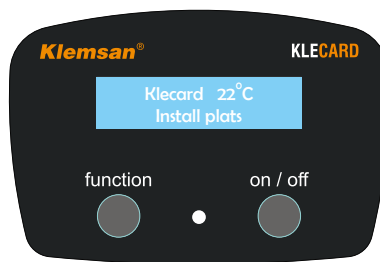

**Printer ON,  
No plate on the tray**

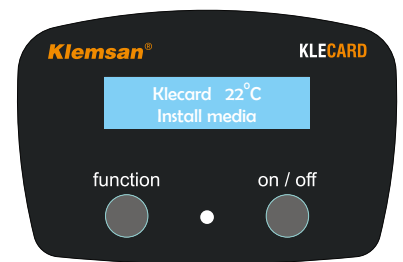

**Printer ON, Plate on the tray  
but no media placed**



**Printer Ready, Media is  
placed on the plate, The LED  
is illuminated**

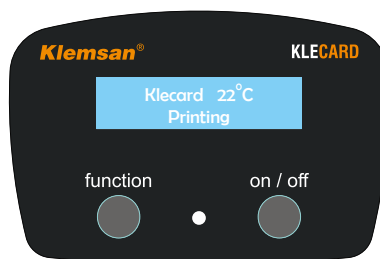

**Printer is operating and it  
prints the job**



**Example of error status**

## Back of the Printer

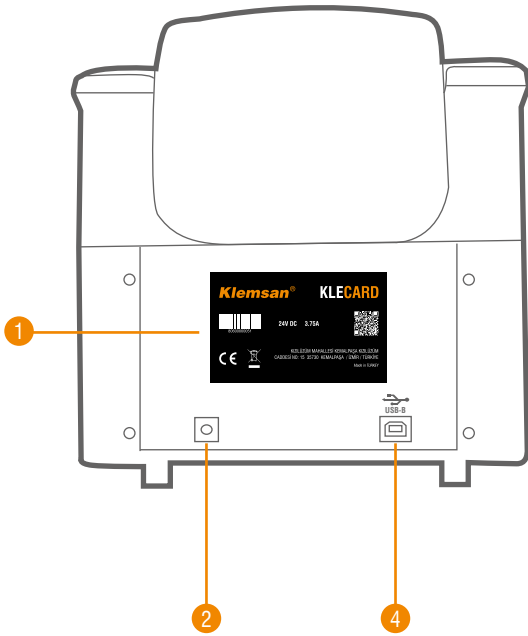

Two input ports of Klecard are located in this section.

The USB port is for the connection to your computer.

The power port is where the printer and the power supply cable are connected.

**\*Please go to page 14, for how to connect cables.**

1	Printer Information
2	Power Port
3	USB Port

## Printer Information Label



The nameplate which is stuck to the back frame of the Klecard contains the main technical information and the Serial Number.

Refer to that Serial Number for servicing.

S/N is made by 11 digits like: 80600000000

## Sensors of the Klecard

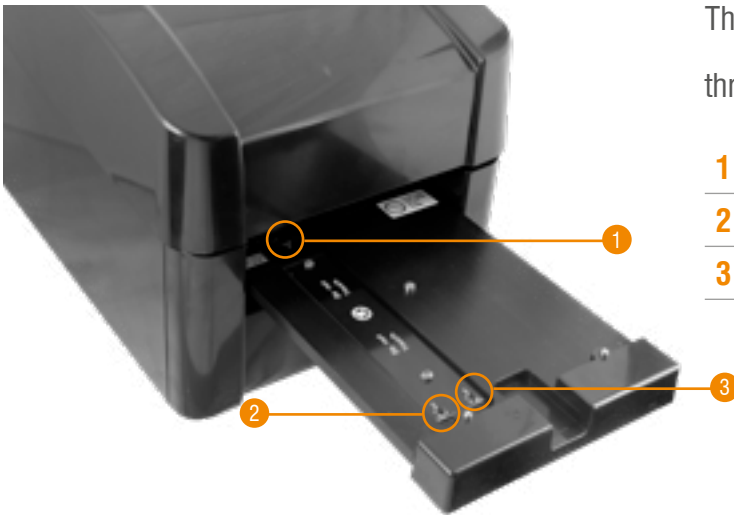

The trayflex contains PCB card on it which there are placed three sensors:

1	Ribbon sensor
2	Plate sensor
3	Media sensor

Because the Klecard printer works with variety of plates and consumables, the plate sensor detects the presence of the plate on the tray. This feature allows using many different types of tags and labels.

After placing the plate, you need to place the media on it. The plates have a hole which is obscured by media.

Thanks to this hole, the printer detects the label and it turns to “**Ready**” status. Now, the printer is ready for the printing.

### TPH Temperature Sensor

There is also another important sensor in the printer, which detects the temperature in the room where the printer is located.

To prevent damage to the printhead and to other electronics components inside the Klecard should operate in the range of **+15°C** and **35°C**.

If the temperature of room is too cold or too warm, the Klecard will not operate and a message will appear on the display. When temperature levels will get back to the accepted range, the printer will operate again.

# Operating of the Klecard Printer

---

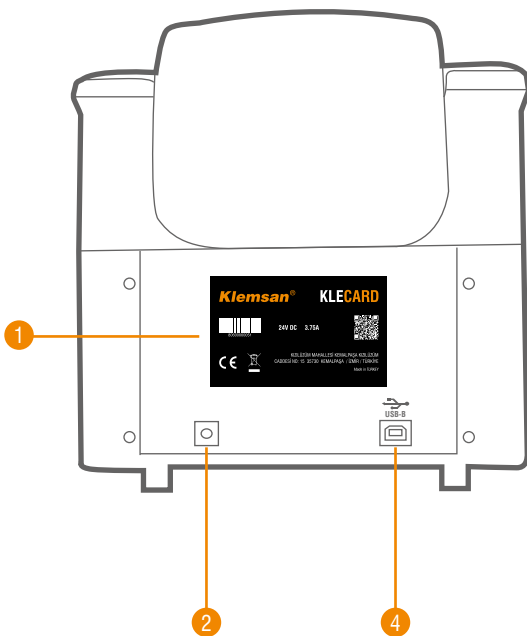

1	Printer Information
2	Power Port
3	USB Port

Please, follow the steps below to set up your printer.

## Connecting the Cables

1 - Connect the USB cable to the port at the back of the printer (left side).

2 - Connect the other end of the USB cable to USB port of your computer.

3 - Connect the power cord to the power supply external unit.

4 - Connect the power supply to the power port at the back of the printer (right side).

5 - Connect the power cord into a suitable electrical outlet.

---

## Energizing the Printer

---

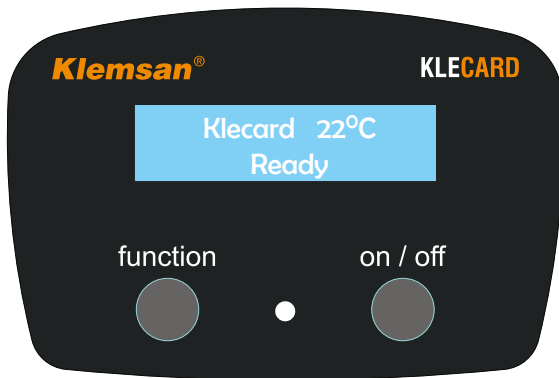

When the printer shows the message **READY**, you can print your job.

**1** - To energize the printer, press the “on/off button” on the right side of the front panel.

With this command, the printer name and the ambient temperature which detected by the sensor appears on the screen.

**2** - After pressing the left function key, the tray is moved and the status of the printer is displayed on the screen.

If plate or media are not installed, follow the instructions at the following page.

**3** - To power of the printer press and hold for 2 seconds the “on/off button” again.

---

## Installing the Plates and the Media

---

1 - To open the printer tray, press the Function Button on the left.

2 - Place the plate on the tray by using the centering pin.

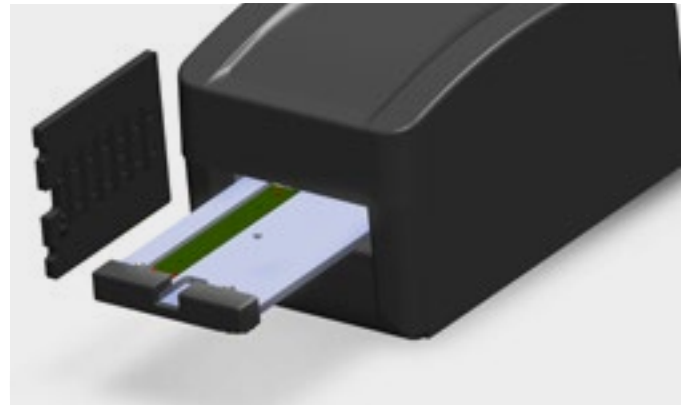

The plates of the Klecard have a unique shape which helps you to place easily them on the tray.

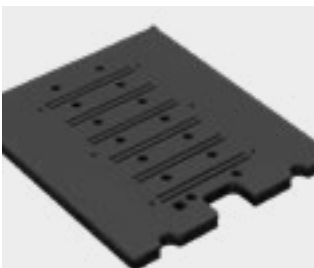

**Plate KL-PLT A for Terminal Block Markers**

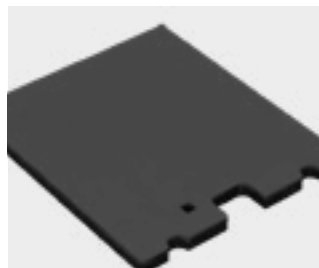

**Plate KL-PLT B for Flat Media**

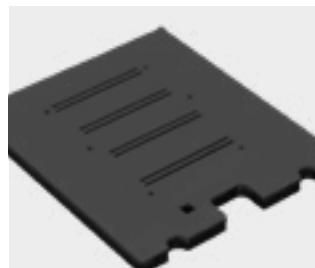

**Plate KL-PLT C for Clip-it Cable Markers**



## Installing the Plates and the Media



**Klecard with terminal block  
plate**

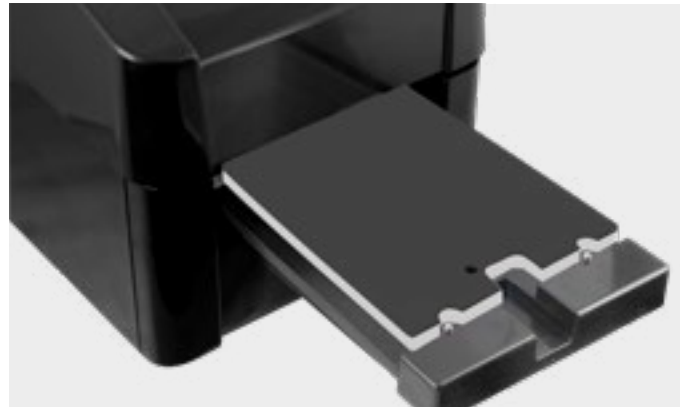

**Klecard with flat media  
plate**

3 - Place the media/label on the plate.

### IMPORTANT

The terminal block and cable marker cards fit the proper plate by placing into plate holes; the flat medias place by attaching them to the two fixing pins on the tray by the help of label holes on top.



**Klecard with terminal block  
plate and card installed**



**Klecard with flat media plate and flat  
consumable installed**

# Setting the Intensity

## Intensity / Darkness Control

The Klecard printer can operate in a large range of room temperature.

The sensor on the printhead detects the room temperature and optimizes the parameters to the default setting level. Despite this, should be required to change the intensity level into the driver to get a better printing quality when the room is too hot or too cold.

When ambient temperature is too hot, the ribbon could stick onto the media. This could affect the ribbon tension and, in general, the quality level on the media. In this case you need to reduce the intensity level.

When ambient temperature is too cold, the ribbon does not stick the label but the darkness level of the print could be weak.

This occurs also when the media are too cold even the room temperature level is acceptable. In this case you need to increase the intensity level.



## IMPORTANT

After installing the printer, go to the Klecard TPC printer properties section in the **Control Panel \ Devices and Printers** of your computer, and change the **Darkness Control** option on the device settings to **By Software**.

**P.S.:** After this feature is activated, you can instantly determine the printing intensity specific to each label type with Klemark Pro software.

When the printer is used continuously, the thermal head temperature of the printer increases.

Therefore, if you are printing many projects consecutively with a constant print intensity, you will need to reduce this intensity after a while.

You may notice this change when the ribbon starts sticking to the label.

# Maintenance of the Klecard

---

## Cleaning the Exterior

Wipe the exterior of the printer with a dry cloth frequently.

## Cleaning the Printhead

Clean the printhead at every ribbon change, or more often if streaks start appearing or the ribbon has torn.

Always clean the thermal head with an IPA (isopropyl alcohol).

Please pay attention during the cleaning process.



- 1 - Move out the tray (if it is inside) by pressing the Function Button.
- 2 - Turn off the printer by pressing the On/Off Button for two second.
- 3 - Remove the top plastic cover.
- 4 - Remove the marking plate from the tray.



The tray should be out as shown.

## Cleaning Method

1 - Use soft materials such as gauze or cotton swab to clean stain or ribbon residue around the heater elements area.

  Do not use re-use gauze, they may cause corrosion in the electrode area.

2 - Use a small amount of absolute ethanol or IPA(isopropyl alcohol) for cleaning.

  Never use cleaners such as acid/alkaline.

3 - Wipe gently in the direction of the heater element line shown as below.

### Wiping direction





### Wrong



## General Recommendations



 Always keep OFF when you are not using Klecard!

  Do not blow off dust on the TPH. Saliva may cause corrosion.

  Do not clean ribbon residue or stain on the heater element line using blades or tools. These actions may cause damage and separation of the protection film on the printhead.

  Do not touch the area around the heater elements with bare hands or dirty gloves.

# Changing the Ribbon

  Make this operation with power OFF.

The ribbon has a length of **300** meters. At the beginning and at the end of it there are two transparent parts (leader and trailer) which helps the user for changing and checking the ribbon.

When the ribbon is missing or finished, the Klecard appears as the picture on the right.

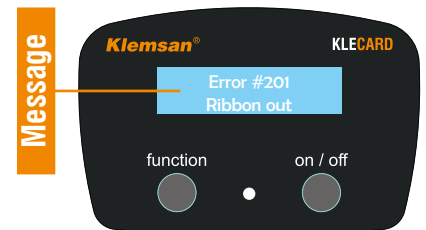

The sensor detects the transparent part and the display show the message: «**Error #201 ribbon out**» or «**Missing Ribbon**».

When the message is shown, the ribbon must be changed by the user.

Please use the tape on the ribbon to stick the Rewind Roller in front of the printer.

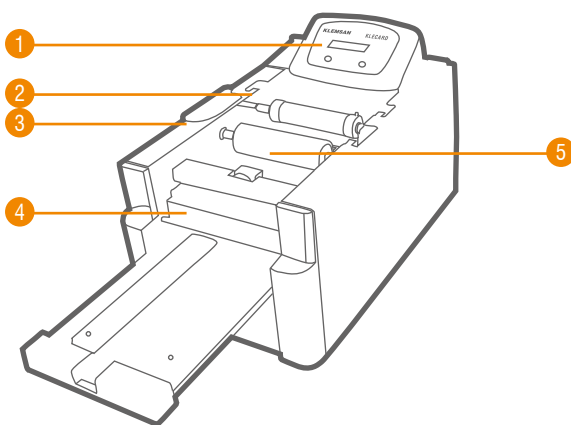

1	Message
2	Supply Roller
3	Gear Cover
4	Missing Ribbon
5	Rewind Roller

**Please follow below steps to replace the ribbon;**

- 1 - Move out the tray (if it is inside) by pressing the Function Button.
- 2 - Turn off the printer by pressing the On/Off Button for two second.
- 3 - Remove the top plastic cover.
- 4 - Remove the marking plate from the tray.
- 5 - Remove the last transparent part of the ribbon from the supply roller.
- 6 - Slide the gear cover far from the frame.
- 7 - Remove the two rollers (supply and take-up) from the printer by lifting them up.
- 8 - Remove the used ribbon from the rewind roller.
- 9 - Remove the empty cardboard core from the supply roller.

## Ribbon Guides

There are three ribbon guides which define the path of the ribbon.

Two of them are in front and one is placed on the back.

## Load a New Ribbon

- 1 - Slide the new ribbon onto the supply roller ,
- 2 - Align the two 90° notches of the cardboard core metal pins on the supply roller.
- 3 - Place a new empty cardboard core onto the rewind roller
- 4 - Align the two 180° notches to the metal pins on the rewind roller.
- 5 - Peel the transparent ribbon leader from the new ribbon.
- 6 - Slide the transparent ribbon leader under the ribbon guides.
- 7 - Slide the transparent part through the lower of the guides and wrap the new cardboard shell with the ribbon (matte side should be face out). Don't forget to tighten the screws!

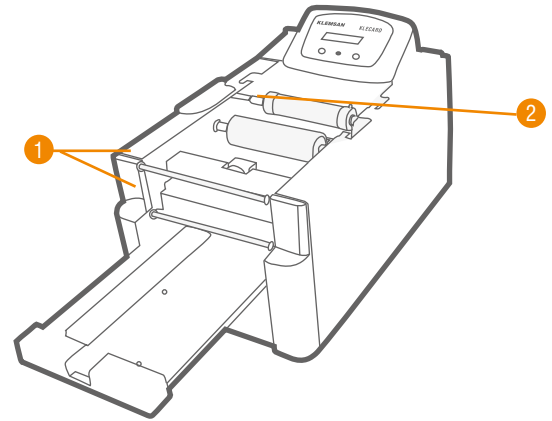

<b>1</b>	Front Guides
<b>2</b>	Back Guide

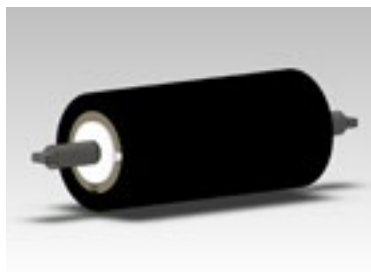

**Rewind roller with new cardboard. Notches are at 180°**

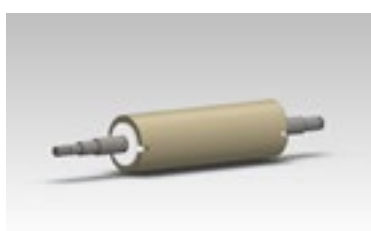

**Supply roller with new ribbon. Notches are at 90°**

Matte side should be face out

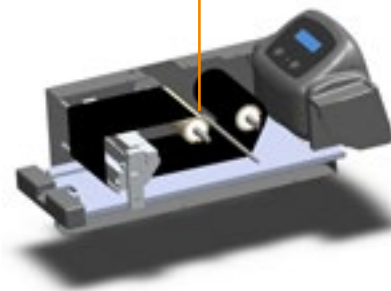

**Correct Ribbon Path**

## IMPORTANT

When you install a new ribbon to the printer, ensure that the colored portion is under the two front ribbon guides.

After following the steps mentioned at the previous page, the Klecard printer is ready to operate.

Now you can place the plate and the media on the tray.

- 1 - Power ON the printer again.
- 2 - Press the Function Button in order to move the tray.
- 3 - Sensors will detect the ribbon and the media.

Now, you can print your job.

## Klecard with a new ribbon installed



Ribbon passes under the front guides



# Troubleshooting

## Error Messages

This is a list of messages that could appear on the LCD display of the Klecard.

When a message is shown on the display, it means that the conditions are not suitable to print your job.

**#201** : Please check the ribbon. It could be broken or missing.

**#204 #205 #206 #207** : Press the Function Button on the left of the control panel. Let the tray goes in and out.

If the message disappear and the printer comes into the “Ready” status again, you can continue to print your job.

**#208 #209 #210 #212 #213** : Check your image and re-send to the printer.

**#214 #215** : Turn off the Klecard, then turn on again. If the messages remain, please contact with the Klemsan Service.

**#216 and #217** : Indicating a situation that the printhead could be damaged due to the room temperature. Klecard is automatically able to stop the print job when conditions are critical and could serious damage the printhead.

If the temperature detected by the Klecard is under -5°C or over +57°C, the printer will stop.

If you are not able to fix the error status, you need to contact with Klemsan Service to get support.

# Error	Message	Hardware Fault Description
201	Ribbon Out	The ribbon is not detected, it is missing or finished.
204	TPH Down	Failed to lower the printhead.
205	TPH Up	Failed to raise the printhead
206	Tray Home	Failed to position the tray to home sensor.
207	Tray Stalled	Tray movement failure detected by sensor.
208	PCL Corrupt	PCL command data is incorrect.
209	PCL Excessive	PCL raster data exceeds printhead capacity.
210	PCL LM Invalid	PCL left margin (LM) value is invalid.
212	PCL Bitmap Wide	Incorrectly formatted bitmap raster line.
213	PCL Bitmap Long	Position beyond the tray length.
214	EEPROM WT	EEPROM is not functioning. Write failure detected.
215	EEPROM RD	EEPROM is not functioning. Read failure detected
216	TPH Hot	Printhead too hot.
217	TPH Cold	Printhead too cold.
222	TPH Replace Soon	Printhead has some elements down

# Printing Issues

---

## A) White line or flaw on printed image :

The most common cause is the presence of foreign substances on the printhead. The solution of this problem is to clean the printhead with IPA (isopropyl alcohol).

**\*Please refer to page 20 and 21 for this purpose.**

! Be careful not to scratch the printhead during cleaning process !

If the white line or flaws remain after cleaning the printhead, it means that there is a damage of the heater elements. In this case you need to replace the printhead. Please contact with the Klemsan Service.

## B) Black line on the printed label :

The possible cause of this problem is a short circuit. This is a real rare case. The only solution is to replace the printhead. Please contact with the Klemsan Service.

## C) Totally white or totally black image :

The possible cause of this problem is a defective connection of the printhead cable. Please check the connection of the cable on the printhead.



Do not **Remove/Insert** the cable when power ON, which may cause damage on the heater elements.

# Safety Information

---







This manual and the indications on the product allow proper and safe operation.

The indication marks that below, help to protect you and other persons from injury, and equipment from damage.

**Warning! Prohibition! Mandatory!**   

According to the international standards, pictograms are used to indicate situations that could result in bodily injury to personnel that operating or maintaining the equipment.

## Safety Precautions

-  Do not disassemble the printer parts or use them for a different purpose. All service procedures should be performed by Klemsan. Do not service the printer with the power cord plugged into the outlet.
-  Do not place or store the printer where children may reach it. Severe injuries and equipment damage may occur if the printer is turned over or falls down.
-  Allow sufficient free space in front of the printer for opening the tray.
-  Do not touch the printer tray while is moving.
-  Do not place your finger into the front opening between the tray and the printing device.
-  Do not revome the Rewind roller when the printer is ON. Do not move the Rewind roller protection when the printer is ON.
-  Maintain the Klecard only with power OFF.

## Safety Testing

Safety Testing This product is in conformity with the provisions of the following European Directives: 2014/30/EU Electromagnetic Compatibility Directive  
2014/35/EU Low Voltage Directive



through compliance with the following European Standards:

EN 55032:2015

EN 55035:2017

EN 60950-1:2006 + A11:2009+ A12:2011 + A1:2010 + A2:2013

The CE mark has been affixed in accordance with the Directives.

## Safety Labels

These two labels are stuck to the printer to advice the users from risks.



Sticked to the cog protection over the rewind roller.

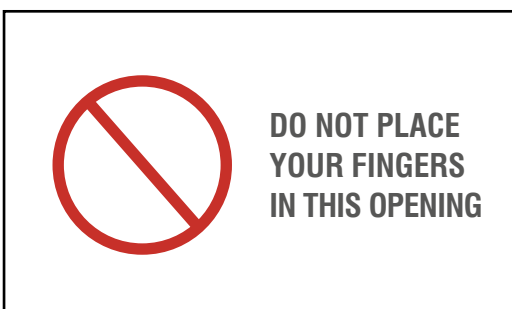
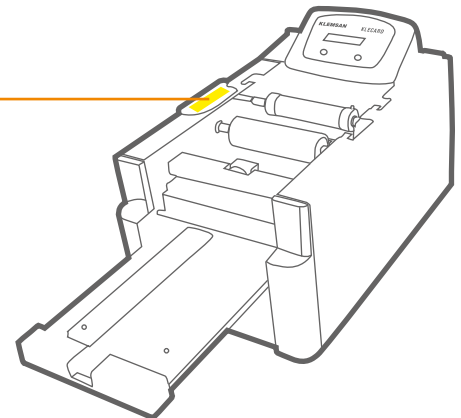

Prohibition label stuck to the tray by the front.

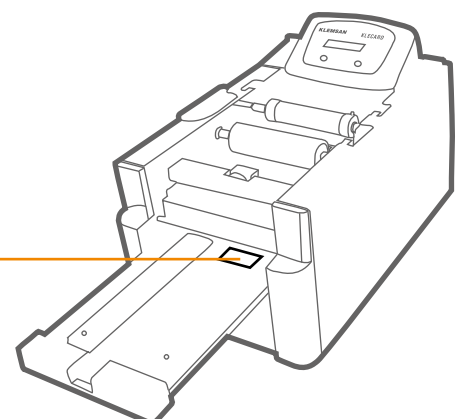

## Warranty

---

Klemsan warrants, to the original end user only, most parts of the Klecard printer for two years, according to the following terms:

- Klemsan will replace or repair, at Klemsan discretion, Klecard's non-consumable parts which were found as defective during the warranty period.
- It's valid from the date of the sale of the product.
- The use of non-Klemsan certified parts may void this warranty.

### **This Warranty does not include the following:**

- Work done at the customer's location.
- Shipment costs of equipment or components returned to the Klemsan factory.
- Software and/or firmware enhancements released after purchase of the product
- Equipment malfunctions as a result of repairs made by technicians who are not authorized or certified by Klemsan.
- Equipment or parts that were tampered with, misused, neglected, or that were modified in any respect without the written consent of Klemsan.
- Equipment or parts that have been damaged due to shipping or accidents, or damaged by lightning, storms, water, or power surges.
- Printer consumables including the print head and ribbon.
- You may not assign this Warranty without Klemsan's written consent.

Klemsan is the intended beneficiary of this Warranty; if there is any inconsistency between this warranty and any other agreement included with or relating to Klemsan products, this warranty shall govern.

If any term of this Warranty is illegal or unenforceable, the legality and enforceability of the remaining provisions are not affected or impaired. This warranty is to be interpreted under the laws of Turkey, without giving effect to conflict of law rules.

Klemsan must receive written notice of any claimed failure to perform or defect within five (5) days after such failure or defect is first observed.

For warranty service, contact your sales representative.

The limited warranty set forth above is Klemsan's only warranty in connection with the Klecard printer.





## Head Office

Kızılızüm Cad. No:15  
Kemalpaşa / Izmir / TURKEY  
Tel : +90 232 877 08 00  
Fax : +90 232 877 08 06

## International Sales Office

Kızılızüm Cad. No:15  
Kemalpaşa / Izmir / TURKEY  
Tel : +90 232 877 08 00  
Fax : +90 232 877 08 06

## Domestic Sales Office

Ahi Evran Cad. No:9 Kat:4  
Maslak / İstanbul / TURKEY  
Tel : +90 212 222 52 00  
Fax : +90 212 222 66 55

## OVERSEAS OFFICES



### Europe

Gsm : +48 51 666 51 41  
Mail : ayhankanal@klemsan.com.tr



### Russian Federation

PJSC KLEMSAN 127566, 44, Altufevskoe  
shosse, Moscow, Russian Federation  
Tel : +7 495 720 67 71  
Mail : russia@klemsan.ru



### Africa & Middle East

Tel : +90 530 401 94 62  
Mail : aliabostiet@klemsan.com.tr



### GCC & India & Pakistan

Gsm : +90 537 870 11 55  
Mail : baranozturk@klemsan.com.tr



### Apac & Ocenia

Gsm : +6698 2495282  
Mail : rabhasiithchatriposayanon@klemsan.com.tr



### Ukraine

6-8A, Yaroslava Ivashkevicha str. Office 7-8,  
04074, Kiev, UKRAINE  
Tel : +380 637 217 185  
Mail : tatyanaozhko@klemsan.com.tr



### Colombia (LATAM)

Gsm : +1 925 315 71 76  
Mail : andresastudillo@klemsan.com.tr

### Mexico

Gsm : +52 55 1200 01 54  
Mail : kellymartinez@klemsan.com.tr



### Usa, Canada

Gsm : + 90 538 843 74 51  
Mail : baranozturk@klemsan.com.tr



### China

Gsm : +90 535 018 49 67  
Mail : egecansahin@klemsan.com.tr